

Aspen

Porcelain tiles



Aspen

Porcelain tiles



45 patterns

19,5 * 121,5 * 1,05 cm | 7 11/16 * 45 13/16 * 7/16"

RECTIFIED	NATURAL PRICE CODE BN60	ANTISLIP PRICE CODE BN95
ASH	23876	-
SAND	23878	-
CAMEL	23877	23880
SMOKE	23879	23881





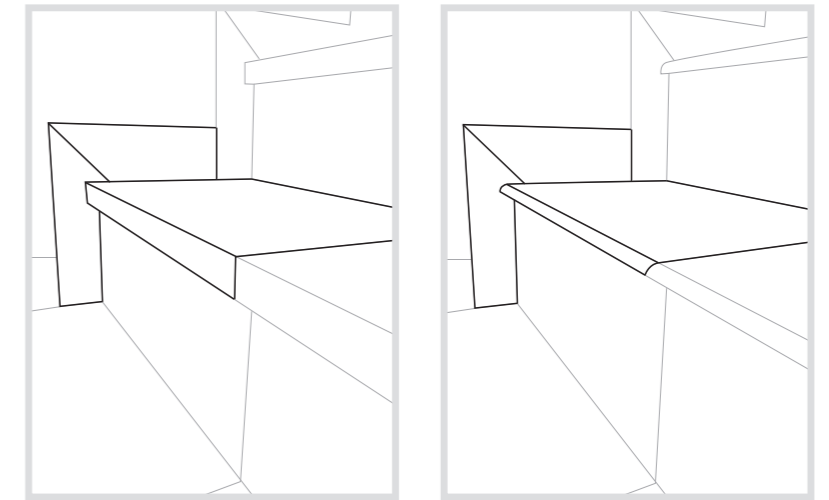

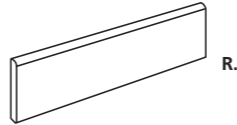
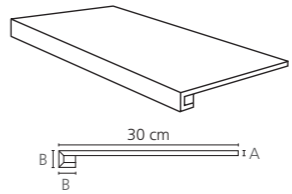
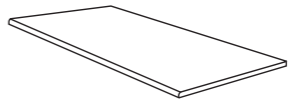
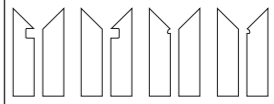

Una pieza, un escalón.
One piece, one step.

NUEVO FORMATO | NEW FORMAT
30*121,5 cm | 11 13/16" * 47 13/16"



PIEZA COMPLEMENTARIA COMPLEMENTARY PIECE			
Rodapie - Skirting  R.	Peldaño técnico - Technical stair - thread  P.	Peldaño romo - Rounded stair - thread  R.P.	*S.K.I. *S.K.D. *Z.R.I. *Z.R.D. 
8*60,7 cm 3 1/8 * 23 7/8" P34	30*121,5 cm 11 13/16 * 47 13/16" P75 A= 1,05 cm B= 3,15 cm A= 7/16" B= 1 1/4"	0*121,5 cm 11 13/16 * 47 13/16" P61	8*30 cm 3 1/8 * 11 13/16" P51

CARACTERÍSTICAS TÉCNICAS ANTIDESLIZAMIENTO ANTI-SLIP CHARACTERISTICS		
Ensayo Essay	Características Features	Resultado Result
DIN 51130	Ángulo crítico (Pies calzados) Critical angle (footwear)	R9
BS-7976-2	Antideslizamiento (Test del péndulo) Slip resistance (Pendulum test)	+30-36 Wet
UNE-ENV-12633	Antideslizamiento (Test del péndulo) Slip resistance (Pendulum test)	Class 1
ANSI A137.1	Coefficiente de Fricción Dinámico Dynamic Coefficient of Friction	> 0,42
ISO 10545-7	Resistencia a la Abrasión Superficial/Resistance to Surface Abrasion	PEI 4

CARACTERÍSTICAS TÉCNICAS TECHNICAL CHARACTERISTICS			
joint 	frost proof 	versatile 	mat 
diferent shades 	shade variation 	various graphics 	various moulds 

APLICACIONES APPLICATIONS		
Área Area	Revestimiento Wall	Pavimento Floor
Interior Internal	✓	✓
Exterior External	✓	✓
Comercial Commercial	✓	-
Ducha Shower	✓	-

EMBALAJE PACKING										
Formato Sizes	Cajas Boxes			Pallet				Cont./20'	Cont./20'	
	Piezas	m ² /sq.m	kg	Cajas	m ² /sq.m	kg	Tamaño cm aprox.	m ² /sq.m	m ² /sq.m	
cm	19,5 * 121,5 * 1,05	3	0,71	17,30	50	35,54	890,00	128 * 95 * 55	858,52	958,35
inch	7 11/16 * 47 13/16 * 7/16	3	7,65	38,06	50	382,54	1958,00	50 3/8 * 37 3/8 * 21 5/8	9241,03	10315,57